

OUTDOOR DECORATIVE CARRAGE II



Approximate Dimensions:

Diameter: 470 mm

Hight: 400 mm

General Data:

Construction:

Body Injection Moulded
Poly-carbonate

Lens / Visor Tempered Glass

IP Rating IP44

Typical

Applications:

General lighting Outdoor
Public

Front View:

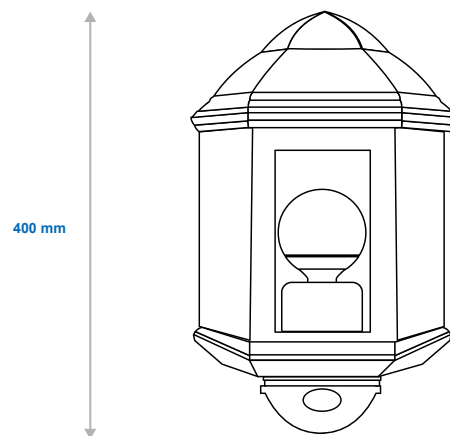

OUTDOOR DECORATIVE CARRAGE II



Options:

.../DNS (Day / Night sensor)

.../E27

.../B22

Product Information:

Product Code	Lamp Watt's	H (mm)	Diameter (mm)	(kg)
CAR-002	42W Halogen	400	470	TBA

Complete your Project:

Please select the items you require and we will be in touch

Cables and Wires:

Indoor
Outdoor
General
Other
Let an ACTOM
Specialist Contact you

Lighting:

Indoor
Outdoor
General
Other
Let an ACTOM
Specialist Contact you

Transformers (Distribution):

Indoor
Outdoor
General
Other
Let an ACTOM
Specialist Contact you

Accessories:

Indoor
Outdoor
General
Other
Let an ACTOM
Specialist Contact you

Specific Information:

Address: 4 Branch Road, Germiston 1401, P.O. Box 678, Germiston 1400

For more Information on this Product Please Send us the Following

Product Information:

Product Name:

Quantity:

Project Name:

Date the Product is required:

Your Contact Information:

Name and Surname:

Company:

Email:

Phone Number:

Province:

Thank You

For having a Look at this Product

Please send this PDF back to us with all your Information

Scan the QR Code to visit our Website:

